

SET-2**Series QQBRR/3**प्रश्न-पत्र कोड
Q.P. Code **31/3/2**

रोल नं.

Roll No.

--	--	--	--	--	--	--	--

परीक्षार्थी प्रश्न-पत्र कोड को उत्तर-पुस्तिका के मुख-पृष्ठ पर अवश्य लिखें ।

Candidates must write the Q.P. Code on the title page of the answer-book.

- कृपया जाँच कर लें कि इस प्रश्न-पत्र में मुद्रित पृष्ठ **15** हैं ।
- प्रश्न-पत्र में दाहिने हाथ की ओर दिए गए प्रश्न-पत्र कोड को परीक्षार्थी उत्तर-पुस्तिका के मुख-पृष्ठ पर लिखें ।
- कृपया जाँच कर लें कि इस प्रश्न-पत्र में **15** प्रश्न हैं ।
- कृपया प्रश्न का उत्तर लिखना शुरू करने से पहले, उत्तर-पुस्तिका में प्रश्न का क्रमांक अवश्य लिखें ।
- इस प्रश्न-पत्र को पढ़ने के लिए 15 मिनट का समय दिया गया है । प्रश्न-पत्र का वितरण पूर्वाह्न में 10.15 बजे किया जाएगा । 10.15 बजे से 10.30 बजे तक छात्र केवल प्रश्न-पत्र को पढ़ेंगे और इस अवधि के दौरान वे उत्तर-पुस्तिका पर कोई उत्तर नहीं लिखेंगे ।
- Please check that this question paper contains **15** printed pages.
- Q.P. Code given on the right hand side of the question paper should be written on the title page of the answer-book by the candidate.
- Please check that this question paper contains **15** questions.
- **Please write down the serial number of the question in the answer-book before attempting it.**
- 15 minute time has been allotted to read this question paper. The question paper will be distributed at 10.15 a.m. From 10.15 a.m. to 10.30 a.m., the students will read the question paper only and will not write any answer on the answer-book during this period.

विज्ञान SCIENCE

निर्धारित समय : 2 घण्टे

Time allowed : 2 hours

अधिकतम अंक : 40

Maximum Marks : 40

31/3/2

1



P.T.O.



सामान्य निर्देश :

निम्नलिखित निर्देशों को बहुत सावधानी से पढ़िए और उनका सख्ती से पालन कीजिए :

- (i) इस प्रश्न-पत्र में कुल 15 प्रश्न हैं। सभी प्रश्न अनिवार्य हैं।
- (ii) यह प्रश्न-पत्र तीन खण्डों में विभाजित किया गया है – क, ख एवं ग।
- (iii) खण्ड क – प्रश्न संख्या 1 से 7 तक लघु-उत्तरीय प्रकार के प्रश्न हैं। प्रत्येक प्रश्न 2 अंकों का है।
- (iv) खण्ड ख – प्रश्न संख्या 8 से 13 भी लघु-उत्तरीय प्रकार के प्रश्न हैं। प्रत्येक प्रश्न 3 अंकों का है।
- (v) खण्ड ग – प्रश्न संख्या 14 और 15 प्रकरण-आधारित प्रश्न हैं। प्रत्येक प्रश्न 4 अंकों का है।
- (vi) कुछ प्रश्नों में आंतरिक चयन प्रदान किया गया है। इस प्रकार के प्रश्नों में केवल एक ही विकल्प का उत्तर दीजिए।

खण्ड क

1. मानव नर के जनन तंत्र के उस भाग/अंग का नाम लिखिए 2
 - (क) जो शुक्राणुओं और मूत्र के प्रवाह का उभय मार्ग है।
 - (ख) जहाँ जनन-कोशिकाओं अथवा शुक्राणुओं का निर्माण होता है।
 - (ग) जिसे शुक्राणुओं के स्थानान्तरण को रोकने के लिए अवरुद्ध कर दिया जाता है।
 - (घ) जो शुक्राणुओं को पोषण प्रदान करता है।
2. (क) मेंडल ने स्थूल रूप से दिखाई देने वाले दो विपर्यासी (विकल्पी) लक्षणों वाले मटर के पौधों के बीच संकरण कराने पर यह पाया कि F_1 संतति में प्राप्त पौधों में कोई भी बीचो-बीच (मिश्रित) लक्षणों वाला पौधा नहीं है। मेंडल के इस प्रेक्षण के कारण की व्याख्या कीजिए। 2

अथवा

- (ख) इस कथन की पुष्टि कीजिए कि “शिशु का लिंग निर्धारण इस तथ्य पर आधारित है कि वह अपने पिता से क्या वंशानुगत करता है”। 2



General Instructions :

Read the following instructions very carefully and strictly follow them :

- (i) This question paper comprises **15** questions. **All** questions are compulsory.
- (ii) This question paper is divided into **three** sections – **A, B** and **C**.
- (iii) **Section A** – Questions No. **1** to **7** are short answer type questions. Each question carries **2** marks.
- (iv) **Section B** – Questions No. **8** to **13** are also short answer type questions. Each question carries **3** marks.
- (v) **Section C** – Questions No. **14** and **15** are case-based questions. Each question carries **4** marks.
- (vi) Internal choices have been provided in some questions. Only one of the alternatives has to be attempted.

SECTION A

1. Name the part/organ of the human male reproductive system 2
- (a) which is a common passage for both sperms as well as urine.
 - (b) where formation of germ cells or sperms takes place.
 - (c) which is blocked to prevent the transfer of sperm.
 - (d) which provides nutrition to the sperms.
2. (a) Mendel crossed two pea plants with visible contrasting characteristics and found that there were no half-way characteristics in the plants of F_1 progeny. Explain the reason for this observation of Mendel. 2

OR

- (b) Justify the statement “Sex of the children will be determined by what they inherit from their father”. 2

31/3/2

3



P.T.O.



3. मानव जनसंख्या के साइज़ को नियंत्रित करने की कोई दो गर्भनिरोधी विधियाँ सुझाइए और उनकी व्याख्या कीजिए । 2
4. कोई तत्व X, जिसकी परमाणु संख्या 24 है, का इलेक्ट्रॉनिक विन्यास लिखिए । स्पष्ट कीजिए कि इस इलेक्ट्रॉनिक विन्यास के आधार पर हम किसी तत्व की संयोजकता, समूह संख्या और आवर्त संख्या किस प्रकार ज्ञात कर सकते हैं । 2
5. निम्नलिखित की इलेक्ट्रॉन-बिन्दु संरचना खींचिए : 2
- (क) बेन्ज़ीन
- (ख) एथेन
6. (क) डिस्पोजेबल कुल्हड़ों (मिट्टी के पात्र) और डिस्पोजेबल कागज़ के कर्पों दोनों का उपयोग प्लास्टिक के डिस्पोजेबल कर्पों के विकल्प के रूप में किया जा रहा है । इन दोनों में से किसे प्लास्टिक के कर्पों के बेहतर विकल्प के रूप में माना जा सकता है और क्यों ? 2

अथवा

- (ख) जैव आवर्धन द्वारा मानव पर सबसे अधिक प्रतिकूल प्रभाव पड़ रहा है । इसका कारण लिखिए । खाद्य पदार्थों (फलों और सब्जियों) की सामान्य धुलाई से जैव आवर्धन के प्रभाव को कम क्यों नहीं किया जा सकता है ? 2
7. (क) अनुमतांक 1100 W का कोई विद्युत् तापक 220 V पर प्रचालित किया गया है । परिकलित कीजिए (i) तापक का प्रतिरोध, तथा (ii) तापक द्वारा ली गई विद्युत् धारा । 2

अथवा

31/3/2

4



-
3. Suggest any two contraceptive methods to control the size of human population and explain them. 2
4. Write the electronic configuration of an element X having atomic number 24. Explain how on the basis of this electronic configuration we can determine the valency, group number and the period number of X. 2
5. Draw the electron dot structure of the following : 2
- (a) Benzene
- (b) Ethane
6. (a) Kulhads (disposable cups made of clay) and disposable paper cups both are used as an alternative for disposable plastic cups. Which one of these two can be considered as a better alternative to plastic cups and why ? 2

OR

- (b) Human beings are most adversely affected by the Biological Magnification. State the reason. Why can ordinary washing of the edibles (fruits and vegetables) not reduce the effect of biological magnification ? 2
7. (a) An electric heater rated 1100 W operates at 220 V. Calculate (i) its resistance, and (ii) the current drawn by it. 2

OR

31/3/2

5



P.T.O.

(ख) नीचे दिए गए विद्युत् परिपथ का तुल्य प्रतिरोध परिकल्पित कीजिए :

2

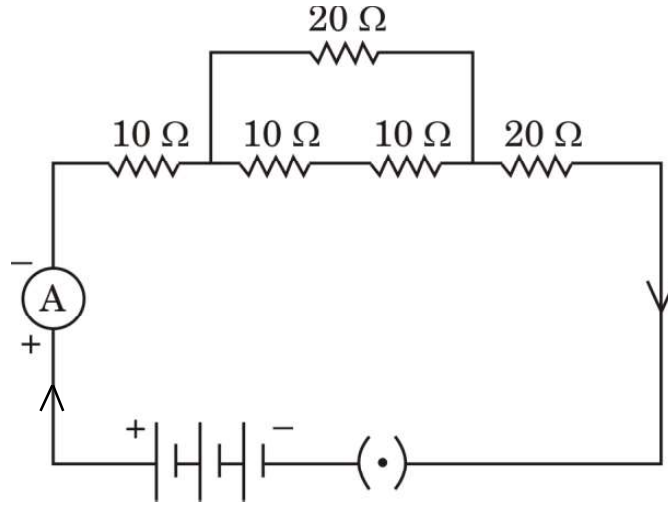

खण्ड ख

8. मेंडल के प्रयोगों ने यह किस प्रकार दर्शाया कि लक्षण स्वतंत्र रूप से वंशानुगत होते हैं ? व्याख्या कीजिए ।

3

9. (क) नीचे दिए गए आरेख में कुण्डली - 1 श्रेणीक्रम में बैटरी और प्लग कुंजी से संयोजित है जबकि कुण्डली - 2 एक गैल्वेनोमीटर से संयोजित है ।

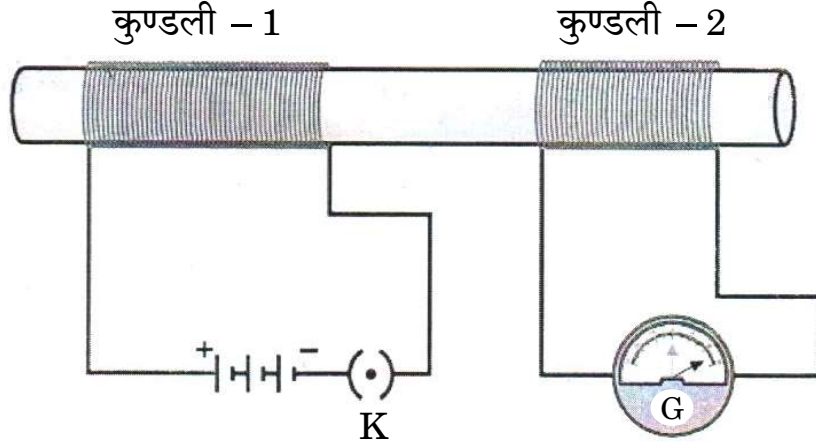

(i) ऐसा क्यों है कि गैल्वेनोमीटर में विक्षेपण केवल उसी समय होता है जब कुंजी (K) को प्लग में लगा रहे होते हैं और उस समय नहीं होता जब परिपथ में स्थायी धारा प्रवाहित होने लगती है ?

(ii) उस समय गैल्वेनोमीटर में क्या प्रेक्षण किया जाता है, जब प्लग से कुंजी को निकाला जाता है ?

(iii) इस क्रियाकलाप के प्रेक्षण के आधार पर निकलने वाला निष्कर्ष लिखिए ।

3

अथवा

31/3/2

6



- (b) Calculate the equivalent resistance of the following electric circuit : 2

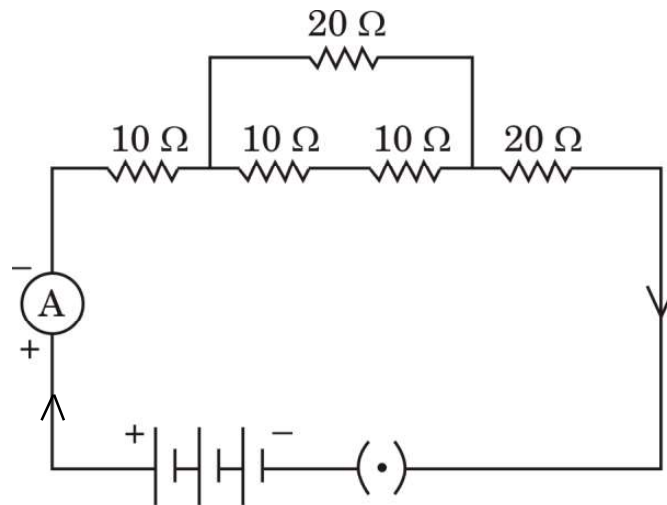

SECTION B

8. How do Mendel's experiments show that the traits are inherited independently? Explain. 3
9. (a) In the diagram given below, Coil - 1 is connected in series with a battery and a plug key while Coil - 2 is connected with a galvanometer. 3

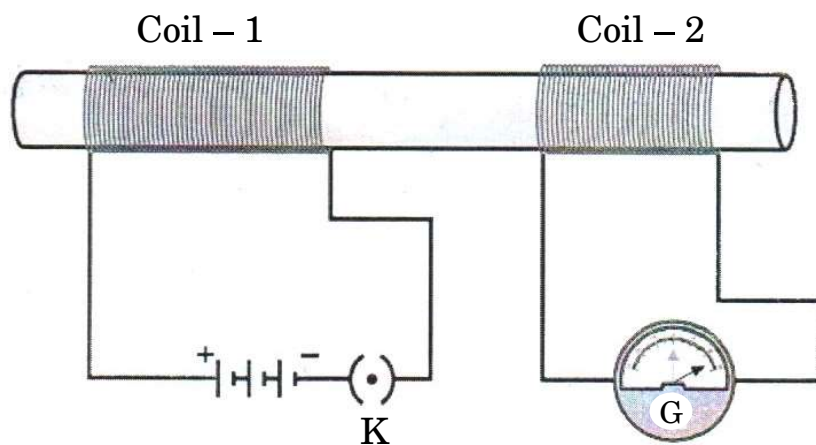

- Why does the galvanometer show deflection only when the key (K) is plugged in and not when a steady current starts flowing in the circuit?
- What is observed in the galvanometer, when the key is plugged out?
- State the conclusion based on the observation of this activity.

OR

31/3/2

7



P.T.O.

(ख) नीचे दिए गए आरेख में, सरल विद्युत् मोटर को दर्शाया गया है :

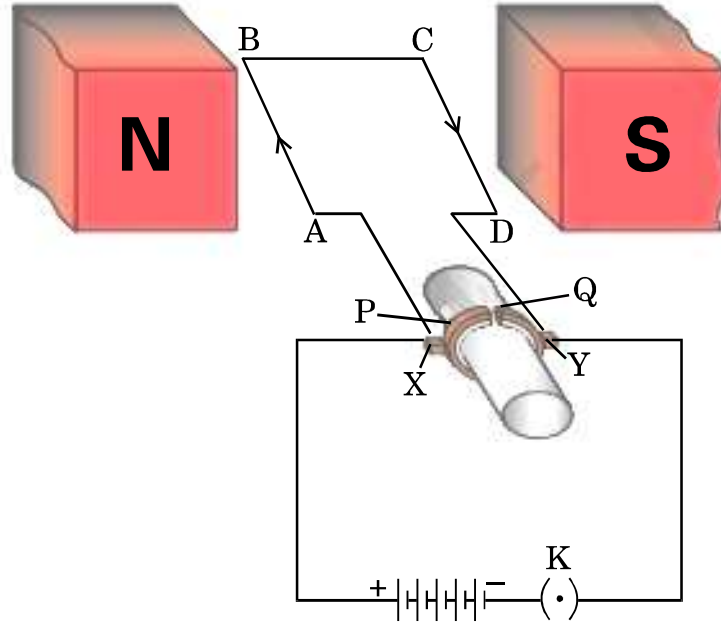

आरेख में दर्शाए अनुसार, कुण्डली ABCD में विद्युत् धारा का प्रवाह भुजा AB में A से B की ओर तथा भुजा CD में C से D की ओर है ।

- भुजा AB और भुजा CD पर लगने वाले बल की दिशाओं का उल्लेख कीजिए ।
- विद्युत् मोटर के उस भाग को पहचानिए और उसका नाम लिखिए जो कुण्डली ABCD में विद्युत् धारा के प्रवाह की दिशा उत्क्रमित कर देता है ।
- कुण्डली ABCD में विद्युत् धारा के प्रवाह की दिशा उत्क्रमित होने के पश्चात् भुजा AB और भुजा CD पर लगने वाले बलों की दिशा लिखिए ।
- किसी चुम्बकीय क्षेत्र में स्थित धारावाही चालक पर लगने वाले बल की दिशा निर्धारित करने वाले नियम का नाम लिखिए ।

3

10. (क) किसी छड़ चुम्बक के चारों ओर चुम्बकीय क्षेत्र रेखाओं का पैटर्न खींचिए । इस पैटर्न पर उत्तर ध्रुव, दक्षिण ध्रुव और सबसे अधिक प्रबलता वाले चुम्बकीय क्षेत्र को अंकित कीजिए ।

(ख) दो चुम्बकीय क्षेत्र रेखाएँ एक-दूसरे का प्रतिच्छेदन क्यों नहीं करती हैं ?

3

31/3/2

8



(b) In the figure given below, a simple electric motor is shown :

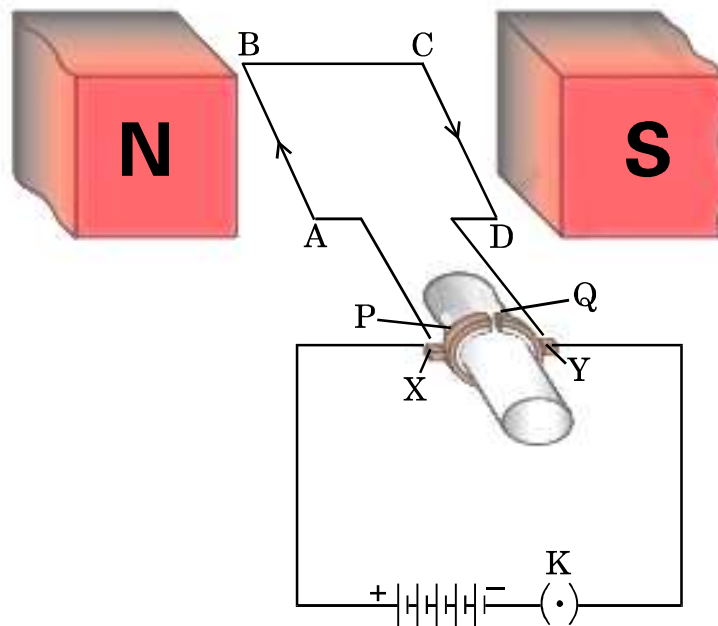

As shown in the figure, the current in the coil ABCD flows from A to B in the arm AB and C to D in the arm CD.

- (i) State the directions in which the arms AB and CD will experience a force.
- (ii) Identify the part of the electric motor that reverses the flow of current in the coil ABCD and write its name.
- (iii) After the reversal of flow of current in the coil ABCD, state the directions in which the arms AB and CD will experience a force.
- (iv) Name the rule which is applied to determine the direction of force on a current carrying conductor placed in a magnetic field.

3

10. (a) Draw the pattern of magnetic field lines around a bar magnet. Mark the position of North Pole, South Pole and the places where the magnetic field is strongest.

(b) Why do the magnetic field lines not intersect each other ?

3

31/3/2

9



P.T.O.

11. नीचे दी गई सारणी में कुछ तत्व किसी विशेष पैटर्न में व्यवस्थित किए गए हैं :

sa (do)	re (re)	ga (mi)	ma (fa)	pa (so)	da (la)	ni (ti)
H	Li	Be	B	C	N	O
F	Na	Mg	Al	Si	P	S
Cl	K	Ca	Cr	Ti	Mn	Fe
Co और Ni	Cu	Zn	Y	In	As	Se
Br	Rb	Sr	Ce और La	Zr	–	–

उस आवर्त नियम को पहचानिए जिससे यह सारणी संबद्ध है । उपर्युक्त आवर्त नियम की दो प्रमुख विशेषताओं और दो विसंगतियों की सूची बनाइए ।

3

12. (क) कारण का उल्लेख कीजिए, ऐसा क्यों है कि

- कार्बन के यौगिकों के गलनांक और क्वथनांक निम्न होते हैं ।
- कार्बन के यौगिक विद्युत् का चालन नहीं करते हैं ।
- कार्बन केवल सहसंयोजी यौगिक बना सकता है ।

3

अथवा

(ख) समजातीय श्रेणी किसे कहते हैं ? किसी समजातीय श्रेणी के दो क्रमागत सदस्यों के आण्विक द्रव्यमानों के बीच अन्तर ज्ञात कीजिए । उल्लेख कीजिए कि कार्बन के यौगिकों की किसी समजातीय श्रेणी में आण्विक द्रव्यमान में वृद्धि होने पर निम्नलिखित गुणधर्मों में किस प्रकार का विचरण होता है :

3

- गलनांक और क्वथनांक
- रासायनिक गुणधर्म

13. कारण सहित व्याख्या कीजिए कि क्यों किसी आहार शृंखला में

- निम्नतर पोषी स्तर से उच्चतर पोषी स्तर पर जाने पर व्यष्टियों की संख्या घटती जाती है, और
- ऊर्जा प्रवाह एकदिशिक है ।

3

31/3/2

10



11. In the following table, some elements have been arranged in a certain pattern :

sa (do)	re (re)	ga (mi)	ma (fa)	pa (so)	da (la)	ni (ti)
H	Li	Be	B	C	N	O
F	Na	Mg	Al	Si	P	S
Cl	K	Ca	Cr	Ti	Mn	Fe
Co and Ni	Cu	Zn	Y	In	As	Se
Br	Rb	Sr	Ce and La	Zr	–	–

Identify the periodic law with which the given table is associated. List two important features and two anomalies of the above periodic law.

3

12. (a) State the reason why

- (i) carbon compounds have low melting and boiling points.
- (ii) carbon compounds do not conduct electricity.
- (iii) carbon can form only covalent compounds.

3

OR

- (b) What is a homologous series ? Find the difference in molecular mass between the two consecutive members of a homologous series. State how in a homologous series of carbon compounds the following properties vary with increase in molecular mass :

3

- (i) Melting and boiling points
- (ii) Chemical properties

13. Explain the reason why in a food chain

- (a) the number of individuals decreases as we move from lower trophic level to higher trophic level, and
- (b) the flow of energy is unidirectional.

3

31/3/2



खण्ड ग

इस खण्ड में 2 प्रकरण-आधारित प्रश्न (14 और 15) हैं। प्रत्येक प्रकरण में 3 उप-भाग (क), (ख) और (ग) हैं। भाग (क) और (ख) अनिवार्य हैं। भाग (ग) में आंतरिक चयन प्रदान किया गया है।

14. वह विधा जिसके द्वारा विभिन्न जीव जनन करते हैं, उनकी शारीरिक अभिकल्प (डिज़ाइन) पर निर्भर करती है। अलैंगिक जनन में, एकल व्यष्टि जनक अपनी संतति (उपज) उत्पन्न करते हैं और युग्मनज सम्मिलित नहीं होते हैं। यह विधि अनुकूल परिस्थितियों में संतति की संख्या में तीव्र वृद्धि करने का एक सामान्य साधन है। अलैंगिक जनन मुख्यतः एककोशिक जीवों, कुछ पौधों और कुछ सरल बहुकोशिक जन्तुओं में होता है।

- (क) पुनर्जनन (पुनरुद्भवन) जनन की प्रक्रिया के समान क्यों नहीं है ? 1
- (ख) कायिक प्रवर्धन द्वारा पौधे उत्पन्न करने के किन्हीं दो लाभों की सूची बनाइए। 1
- (ग) (i) हाइड्रा में मुकुलन की प्रक्रिया की व्याख्या कीजिए। 2

अथवा

- (ii) क्या होता है जब
- (I) स्पाइरोगायरा तन्तु विकसित होकर काफी लम्बा हो जाता है, और
- (II) कोई बीजाणुधानी राइज़ोपस में विकसित होकर फट जाती है ? 2



SECTION C

*This section has 2 case-based questions (14 and 15). Each case is followed by 3 sub-questions (a), (b) and (c). Parts (a) and (b) are **compulsory**. However, an internal choice has been provided in Part (c).*

14. The modes by which various organisms reproduce depend on the body design of the organisms. In asexual reproduction, a single individual parent produces offsprings without the involvement of gametes. This method is a common means of increasing the offsprings rapidly under favourable conditions. Asexual reproduction occurs mostly in unicellular organisms, some plants and certain simple multicellular animals.

- (a) Why is regeneration not same as reproduction ? 1
- (b) List any two advantages of producing plants through vegetative propagation. 1
- (c) (i) Explain the process of budding in Hydra. 2

OR

- (ii) What happens when
- (I) a spirogyra filament matures and attains a considerable length, and
- (II) a sporangia in Rhizopus bursts on maturation ? 2

31/3/2

13



P.T.O.



15. नीचे दिए गए विद्युत् परिपथ का अध्ययन कीजिए जिनमें प्रतिरोधक तीन भुजाओं A, B और C में व्यवस्थित हैं :

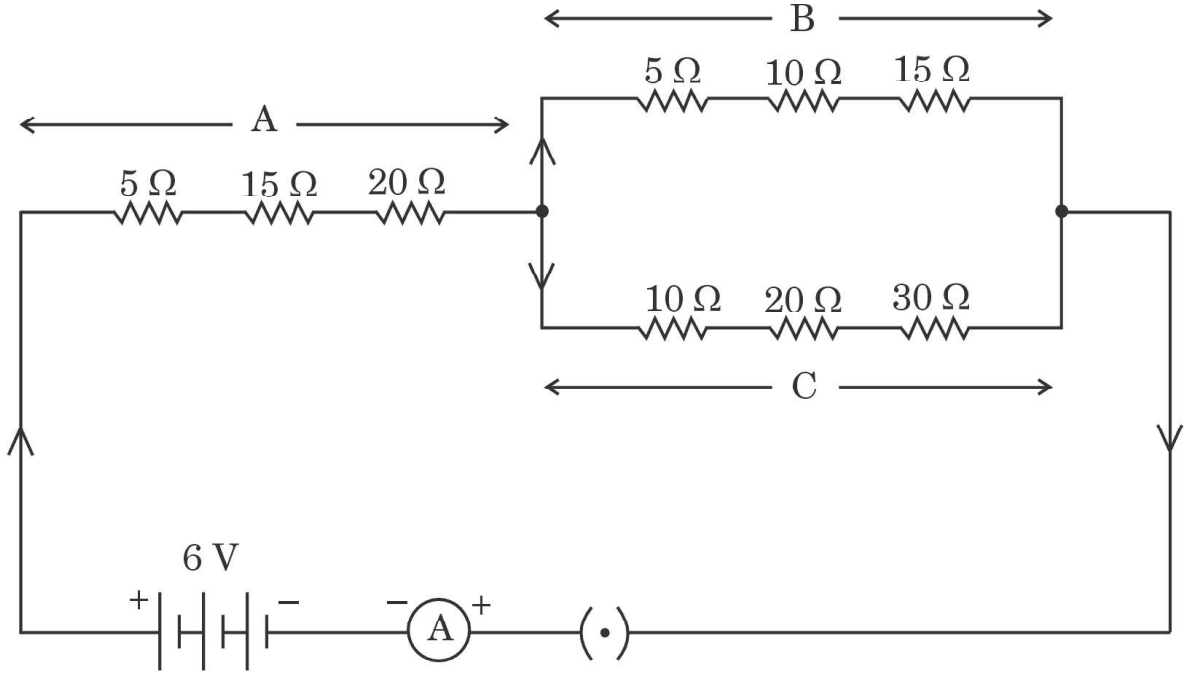

- (क) भुजा B का तुल्य प्रतिरोध ज्ञात कीजिए । 1
- (ख) भुजा B और भुजा C के पार्श्व संयोजन का तुल्य प्रतिरोध परिकलित कीजिए । 1
- (ग) (i) ऐमीटर में प्रवाहित धारा निर्धारित कीजिए । 2

अथवा

- (ii) यदि इस परिपथ से भुजा B को हटा दिया जाए, तो ऐमीटर में प्रवाहित धारा निर्धारित कीजिए । 2



15. Study the following electric circuit in which the resistors are arranged in three arms A, B and C :

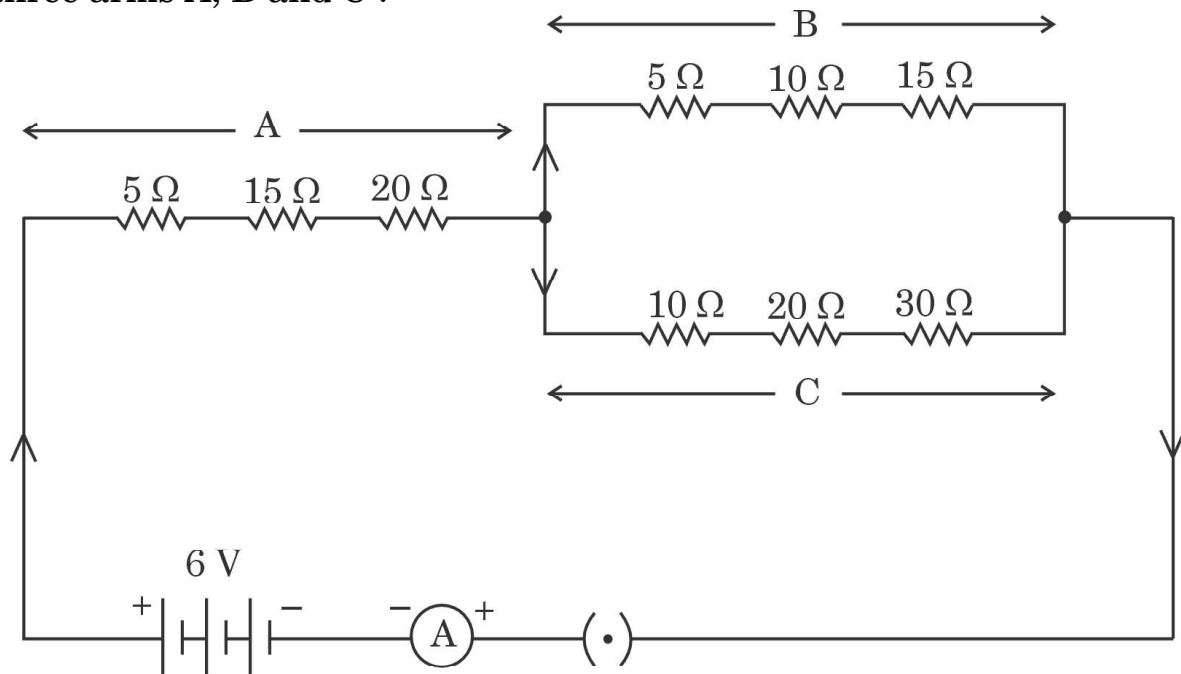

- (a) Find the equivalent resistance of arm B. 1
- (b) Calculate the equivalent resistance of the parallel combination of the arms B and C. 1
- (c) (i) Determine the current that flows through the ammeter. 2

OR

- (ii) Determine the current that flows in the ammeter when the arm B is withdrawn from the circuit. 2

31/3/2



Strictly Confidential: (For Internal and Restricted use only)
Class : X Secondary School Term II Examination, 2022
Marking Scheme – Science SUBJECT CODE -086
(PAPER CODE –31/3/3)

General Instructions: -

1. You are aware that evaluation is the most important process in the actual and correct assessment of the candidates. A small mistake in evaluation may lead to serious problems which may affect the future of the candidates, education system and teaching profession. To avoid mistakes, it is requested that before starting evaluation, you must read and understand the spot evaluation guidelines carefully.
2. **“Evaluation policy is a confidential policy as it is related to the confidentiality of the examinations conducted, Evaluation done and several other aspects. Its’ leakage to public in any manner could lead to derailment of the examination system and affect the life and future of millions of candidates. Sharing this policy/document to anyone, publishing in any magazine and printing in News Paper/Website etc may invite action under IPC.”**
3. Evaluation is to be done as per instructions provided in the Marking Scheme. It should not be done according to one’s own interpretation or any other consideration. Marking Scheme should be strictly adhered to and religiously followed. **However, while evaluating, answers which are based on latest information or knowledge and/or are innovative, they may be assessed for their correctness otherwise and marks be awarded to them. In class-X, while evaluating two competency based questions, please try to understand given answer and even if reply is not from marking scheme but correct competency is enumerated by the candidate, marks should be awarded.**
4. The Head-Examiner must go through the first five answer books evaluated by each evaluator on the first day, to ensure that evaluation has been carried out as per the instructions given in the Marking Scheme. The remaining answer books meant for evaluation shall be given only after ensuring that there is no significant variation in the marking of individual evaluators.
5. Evaluators will mark(\checkmark) wherever answer is correct. For wrong answer ‘X’ be marked. Evaluators will not put right kind of mark while evaluating which gives an impression that answer is correct and no marks are awarded. **This is most common mistake which evaluators are committing.**
6. If a question has parts, please award marks on the right-hand side for each part. Marks awarded for different parts of the question should then be totalled up and written in the left-hand margin and encircled. This may be followed strictly.
7. If a question does not have any parts, marks must be awarded in the left-hand margin and encircled. This may also be followed strictly.
8. If a student has attempted an extra question, answer of the question deserving more marks should be retained and the other answer scored out.
9. No marks to be deducted for the cumulative effect of an error. It should be penalized only once.
10. A full scale of marks **40** has to be used. Please do not hesitate to award full marks if the answer deserves it.
11. Every examiner has to necessarily do evaluation work for full working hours i.e. 8 hours every day and evaluate 30 answer books per day in main subjects and 35 answer books per day in other subjects (Details are given in Spot Guidelines). This is in view of the reduced syllabus and number of questions in question paper.



12. Ensure that you do not make the following common types of errors committed by the Examiner in the past:-
- Leaving answer or part thereof unassessed in an answer book.
 - Giving more marks for an answer than assigned to it.
 - Wrong totalling of marks awarded on a reply.
 - Wrong transfer of marks from the inside pages of the answer book to the title page.
 - Wrong question wise totalling on the title page.
 - Wrong totalling of marks of the two columns on the title page.
 - Wrong grand total.
 - Marks in words and figures not tallying.
 - Wrong transfer of marks from the answer book to online award list.
 - Answers marked as correct, but marks not awarded. (Ensure that the right tick mark is correctly and clearly indicated. It should merely be a line. Same is with the X for incorrect answer.)
 - Half or a part of answer marked correct and the rest as wrong, but no marks awarded.
13. While evaluating the answer books if the answer is found to be totally incorrect, it should be marked as cross (X) and awarded zero (0) Marks.
14. Any unassessed portion, non-carrying over of marks to the title page, or totalling error detected by the candidate shall damage the prestige of all the personnel engaged in the evaluation work as also of the Board. Hence, in order to uphold the prestige of all concerned, it is again reiterated that the instructions be followed meticulously and judiciously.
15. The Examiners should acquaint themselves with the guidelines given in the Guidelines for spot Evaluation before starting the actual evaluation.
16. Every Examiner shall also ensure that all the answers are evaluated, marks carried over to the title page, correctly totalled and written in figures and words.
17. The Board permits candidates to obtain photocopy of the Answer Book on request in an RTI application and also separately as a part of the re-evaluation process on payment of the processing charges.



MARKING SCHEME
SECONDARY SCHOOL EXAMINATION TERM-II, 2022
SUBJECT : SCIENCE CODE-086
[PAPER CODE : 31/3/3]

Instructions:-

- The marking scheme carries only suggested value points for the answers.
- These are only guidelines and do not constitute the complete answer.
- The students can have their own expression and if the expression is correct, the marks are awarded accordingly.

Maximum Marks : 40

Q. No.	EXPECTED ANSWER / VALUE POINTS	Marks	Total Marks
	SECTION—A		
1.	<p>(a) $P(\text{Power}) = V(\text{Potential difference}) \times I(\text{Current})$ Here $P = 1100 \text{ W}$, $V = 220 \text{ V}$, $I = ?$, $R = ?$</p> $P = \frac{V^2}{R}$ <p>(i) $R = \frac{V^2}{P}$</p> $= \frac{220^2 \text{ V} \times 220 \text{ V}}{11000 \text{ W}}$ $= 44 \Omega$ <p>(ii) $I = \frac{V}{R}$</p> $I(\text{Current}) = \frac{V}{R} = \frac{220 \text{ V}}{44 \Omega} = 5 \text{ A}$ <p style="text-align: right;">(Accept any other alternative method) OR</p> <p>(b) $R_S = R_3 + R_4 = 10 + 10 = 20 \Omega$</p> $\frac{1}{R_P} = \frac{1}{R_2} + \frac{1}{R_S}$ $= \frac{1}{20} + \frac{1}{20} = \frac{1}{10} \Omega$ <p>$R_P = 10 \Omega$</p> <p>Total equivalent resistance = $R = R_1 + R_P + R_5$</p> $= R = 20 + 10 + 10 = 40 \Omega$	<p>$\frac{1}{2}$</p> <p>$\frac{1}{2}$</p> <p>$\frac{1}{2}$</p> <p>$\frac{1}{2}$</p> <p>$\frac{1}{2}$</p> <p>$\frac{1}{2}$</p> <p>$\frac{1}{2}$</p> <p>$\frac{1}{2}$</p>	2

2.	<p>(i) Down the group the effective nuclear charge experienced by valence electron is decreasing because the outer most electron are further away from the nucleus. Therefore, these can be lost easily.</p> <p>(ii) Effective nuclear charge acting on the valence shell electrons increases across a period. The tendency to lose electron will decrease.</p>	1	
		1	2
3.	<p>Structural isomers of butane</p> <div style="display: flex; justify-content: space-around; align-items: center;"> <div style="text-align: center;"> $\begin{array}{cccc} & \text{H} & \text{H} & \text{H} & \text{H} \\ & & & & \\ \text{H} & -\text{C} & -\text{C} & -\text{C} & -\text{C}-\text{H} \\ & & & & \\ & \text{H} & \text{H} & \text{H} & \text{H} \end{array}$ </div> <div style="font-size: 2em;">/</div> <div style="text-align: center;"> $\text{CH}_3-\text{CH}_2-\text{CH}_2-\text{CH}_3$ </div> </div> <div style="display: flex; justify-content: space-around; align-items: center;"> <div style="text-align: center;"> $\begin{array}{ccc} & \text{H} & \text{H} & \text{H} \\ & & & \\ \text{H} & -\text{C} & -\text{C} & -\text{C}-\text{H} \\ & & & \\ & \text{H} & & \text{H} \\ & \text{H}-\text{C}-\text{H} & & \\ & & & \\ & \text{H} & & \end{array}$ </div> <div style="font-size: 2em;">/</div> <div style="text-align: center;"> $\begin{array}{c} \text{CH}_3-\text{CH}-\text{CH}_3 \\ \\ \text{CH}_3 \end{array}$ </div> </div>	1	
		1	2
4.	<p>(a) • Disposable paper cups.</p> <ul style="list-style-type: none"> • Making of Kulhads on a large scale would result in the loss of fertile top soil. /Disposable paper cups can easily decompose and do not pollute the environment. <p style="text-align: center;">(or any other suitable answer)</p> <p style="text-align: center;">OR</p> <p>(b) • Human beings occupy the top level in any food chain therefore maximum concentration of these chemicals get accumulated in our bodies.</p> <ul style="list-style-type: none"> • Harmful chemicals or pesticides get absorbed from the soil by the plants along with water and minerals therefore ordinary washing cannot remove these harmful chemicals. 	1	
		1	
		1	
5.	<p>(a) i) Part—D Anther /Stamen</p> <p>ii) Part—A Stigma</p> <p>(b) Ovule converts into Seed; Ovary converts into Fruit</p>	$\frac{1}{2}$	
		$\frac{1}{2}$	
		$\frac{1}{2} + \frac{1}{2}$	2
6.	<ul style="list-style-type: none"> • Barrier method : Prevents the meeting of sperms with ova 		

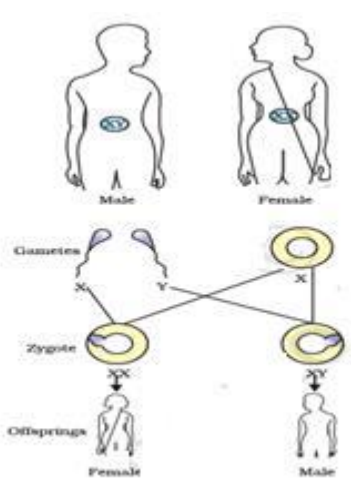

	<ul style="list-style-type: none"> • Oral pills/Chemical method : Changes the hormonal balance in females so eggs are not released • Copper T or loop : to prevent pregnancy/to prevent fusion of male & female gametes • Surgical method : To block vas deferens in males or fallopian tube in females to prevent fertilization <p style="text-align: right;">(Any two)</p>	1+1	2
7.	<p>(a)</p> <ul style="list-style-type: none"> • No halfway characteristics were found in the F₁ generation because the F₁ progeny is a mixture of contrasting traits of the parents but only one of the character of the parents gets expressed in F₁ progeny. • The character that gets expressed is a dominant trait and that which does not get expressed in the presence of dominant trait is a recessive trait. <p style="text-align: center;">OR</p> <p>(b) Mother has XX chromosome. Father has XY chromosome. All children inherit X chromosome from mother. The one who inherits X chromosome from father will be a girl and one who inherits Y chromosome from the father will be a boy. /</p>  <p style="text-align: center;">(Full credit for diagrammatic expression)</p>	1 1 $\frac{1}{2}$ $\frac{1}{2}$ 1	2
SECTION-B			
8.	<p>Newland's Law of Octaves</p> <p>Important features:</p> <ol style="list-style-type: none"> 1. The elements were arranged in the order of their increasing atomic mass. 2. Every eighth element has properties similar to the first element. 	1 $\frac{1}{2}$	

	<p>Anomalies:</p> <ol style="list-style-type: none"> 1. It was assumed that only 56 elements existed in nature and new elements would not be discovered in future. 2. Unlike elements were put in the same slot/note. <p style="text-align: right;">(Or any other)</p>	<p>½</p> <p>½</p> <p>½</p>	3
9.	<ul style="list-style-type: none"> • Mendel crossed two pea plants with two different visible contrasting characteristics such as plant with round and green seeds, with plant with wrinkled, yellow seeds. In F₁ progeny all obtained plants have round and yellow seeds which are dominant characters. • F₁ progeny is self-pollinated to produce F₂ progeny and the plant produced in F₂ progeny showed new combination such as plant with round and yellow seeds or plant with wrinkled and green seeds which were not present in parent generation or F₁ progeny. <p>The ratio obtained was 9 round yellow, 3 round green, 3 wrinkled yellow, 1 wrinkled green. Thus, traits are independently inherited.</p> <p style="text-align: center;">(Full marks should be given if diagrammatically represented)</p>	<p>1</p> <p>1</p> <p>1</p>	3
10.	<p>(a)</p> <ul style="list-style-type: none"> • The microorganisms, that break down the dead remains and waste products of organisms into simpler substances. • Break down the complex organic wastes into simpler substances and return the nutrients to the soil so that these can be used again by the plants. <p>(b) Decomposers are not able to break down the plastics into its constituents therefore plastics cannot be decomposed. / Plastics are non-bio degradable.</p>	<p>1</p> <p>1</p> <p>1</p>	3
11.	<p>(a)</p> <ol style="list-style-type: none"> (i) The forces of attraction between the molecules are weak. (ii) Bonding in carbon compounds does not give rise to any charged particles. (iii) Carbon only shares electrons with other atoms. It is not able to lose four electrons or gain four electrons. <p style="text-align: center;">OR</p> <p>(b)</p> <ul style="list-style-type: none"> • A series of compounds in which some functional groups substitute for hydrogen in a carbon chain / the consequent members differ by -CH₂ unit (14 u) • Difference of CH₂ = 12u + 2u = 14u <ol style="list-style-type: none"> (i) Melting and boiling points increase with increase in molecular mass. 	<p>1</p> <p>1</p> <p>1</p> <p>1</p> <p>1</p> <p>1</p> <p>½</p>	

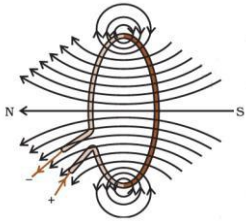

	(ii) Chemical properties, determined by the functional group remain same in a homologous series.	1/2	3
12.	<p>(a) Pattern of magnetic field</p>  <p>1 mark for correct representation of direction of magnetic field lines and current.</p> <p>(b) Right-hand thumb rule : Hold a current carrying straight conductor in your righthand such that the thumb points towards the direction of current, then your fingers will wrap around the conductor in the direction of the field lines of the magnetic field.</p>	1 1 1	3
13.	<p>(a) (i) • When the key is plugged-in, current starts in coil-1, the magnetic field around the coil is changed. This produces induced current in the coil – 2 and galvanometer shows deflection • There is no change in magnetic field when a steady current starts flowing in the circuit.</p> <p>(ii) Galvanometer shows deflection in the opposite direction.</p> <p>(iii) Conclusion: Induced current is produced only when there is a change in magnetic field which occurs only when the key is plugged in or plugged out.</p>	1 1 1	3
13.	<p style="text-align: center;">OR</p> <p>(b)</p> <p>(i) Arm AB—Downward, Arm CD—Upward</p> <p>(ii) P and Q—Split ring / Commutator</p> <p>(iii) Arm AB upward, Arm CD downward/Direction of force will get reversed</p> <p>(iv) Fleming’s left-hand rule</p>	1/2+1/2 1/2, 1/2 1/2 1/2	
SECTION—C			
14.	<p>(a) $R = R_1 + R_2 + R_3$ $= 10\Omega + 20\Omega + 30\Omega$ $= 60\Omega$</p> <p>(b) $\frac{1}{R_p} = \frac{1}{R_B} + \frac{1}{R_C}$</p>	1 1/2	



	$\frac{1}{R_p} = \frac{1}{30\Omega} + \frac{1}{60\Omega}$ $R_p = 20\Omega$ <p>(c) (i) $R = R_s + R_p$ $= 40\Omega + 20\Omega = 60\Omega$ $\therefore I = \frac{V}{R} = \frac{6V}{60\Omega} = \frac{1}{10} A = 0.1 A$</p> <p style="text-align: center;">OR</p> <p>(c) (ii) <i>Resistance</i>, $R = 40\Omega + 60\Omega = 100\Omega$ $\therefore I = \frac{V}{R} = \frac{6V}{100\Omega} = 0.06 A$</p>	$\frac{1}{2}$ 1 $\frac{1}{2} + \frac{1}{2}$ 1 $\frac{1}{2} + \frac{1}{2}$	4
15.	<p>(a) Leishmania, Kala-azar</p> <p>(b) Buds produced in the notches of leaf margins of 'Bryophyllum' develop into new plants, whereas Banana leaves do not have buds in their leaves.</p> <p>(c) (i) Bud develops as an outgrowth due to repeated cell division at one specific site, these buds develop into tiny individuals, and when fully mature detach from the parent body and become new independent individuals. (Marks should be awarded if a student draws a well labelled diagram)</p> <p style="text-align: center;">OR</p> <p>(c) (ii) (I) The filament breaks into smaller pieces or fragments and each fragment grows into new individuals. (II) It releases spores which germinate and eventually develops into new Rhizopus individuals.</p>	1 1 2 1 1	4

* * *